

NORMALISED ELECTRICAL TESTS

Those tests allow to check, when a product is manufactured (production line or laboratory), whether the protection against electrical shocks is convenient, but also the components quality and user safety. We list below the most popular standards concerned by safety testing :

- **EN60065 SAFETY FOR AUDIO, VIDEO AND SIMILAR ELECTRONIC APPARATUS**
example : amplifiers, radio receivers, antenna amplifiers, electronic music devices, rythme generator, ...
- **EN60204-1 SAFETY OF MACHINERY**
example : metal, wood, textile, leather machines, handling equipment, lifts, ...
- **EN60335-1 SAFETY OF HOUSEHOLD AND SIMILAR ELECTRICAL APPLIANCES**
example : coffee machines, dish washers, washing machines, ...
- **EN60598-1 SAFETY OF LIGHTING EQUIPMENT**
example : lampholders, lights, flourescent lights, sodium lights, electronic ballast, ...
- **EN60601-1 SAFETY OF MEDICAL ELECTRICAL EQUIPMENT**
example : surgery equipment, dentist equipment, scanners, ...
- **EN60950 SAFETY OF INFORMATION TECHNOLOGY EQUIPMENT**
example : typewriters, erasers, accounting machines, modems, telephone answering machines, ...
- **EN61010-1 SAFETY FOR ELECTRICAL EQUIPMENT FOR MEASUREMENT, CONTROL AND LABORATORY USE**
example : regulation equipment, measure equipment, electrical equipment for laboratories, safety testers, ...
- **EN61131-2 SAFETY FOR AUTOMATONS**
example : programmable controllers, ...
- **CEI990 TECHNICAL REPORT – METHODS OF MEASUREMENT OF TOUCH-CURRENT AND PROTECTIVE CONDUCTOR CURRENT**
This report is a reference for leakage current, and will become in the future the only standards for leakage (slowly, all the standards are referring to this one)



Last update: 18/05/05
v.3

Help file for most popular standards

1

MAIN ELECTRICAL SAFETY TESTS

- GROUND CONTINUITY TEST
 - HIPOT TEST
 - INSULATION TEST
 - LEAKAGE CURRENT MEASUREMENT
- OTHER TESTS we can do: power measurement, cos φ, engine ignition, engine and transformer overloads, functional tests, ... and many more based on customer requirements

Standard	Application field	Ground	Insulation	Hipot	Leakage	Needed insulation transformer for Leakage test ?	Test voltage to be applied for leakage test :
EN60065	Automatons	Yes ¹	Yes	Yes	Yes	compulsory	Un x 0.9 or Un x 1.06
EN60204-1	industrial equipment	Yes	Yes	Yes	No	No	No test
EN60335-1	household and similar appliances - <i>electrodomestic</i>	Yes	Yes	Yes	Yes	compulsory	Un and Un x 1.06
EN60598-1	Lights	Yes	Yes	Yes	Yes	compulsory	Un
EN60601-1	medical (leakage to earth only)	Yes	No	Yes	Yes	compulsory	Un x 1.10
EN60601-1	medical (leakage to patient and earth)	Yes	No	Yes	Yes	compulsory	Un x 1.10
EN60950	information technology	Yes	Yes	Yes	Yes	compulsory	Un
EN61010-1	measurement control and laboratory equipment	Yes	No	Yes	Yes	compulsory	Un x 1.10
EN61131-2	safety for automatons	Yes	No	Yes	No	No	No test

¹ : Continuity test compulsory since 2001

GROUND CONTINUITY TEST

GOAL: check that all the touch accessible parts are properly connected to the protective earth connection.

PRINCIPLE: Apply a current in between each metallic accessible part and the earth protection connection, then measure the voltage in between those two parts and check with the Ohmic law that the calculated resistance is lower than the value required by the standard. The DUT is not connected to mains!

TEST CONDITIONS (according to the main standards):

- ◆ Current 10, 25 A AC or DC, or 2 x In
- ◆ Voltage from 6 to 12 volts AC or DC
- ◆ Resistance < 0, 1Ω, 0, 2 Ω or 0, 5 Ω
- ◆ Time > 5 s, 1mn or not defined

Test parameters

	EN60065	EN60204-1	EN60335-1	EN60598-1	EN60601-1	EN60950	EN61010-1	EN61131-2
Voltage	< 12 V	Not defined	12 V eff	< 12 V	6 V	< 12 V	10 V eff /=	< 12 V
Current	25 A eff /=	Not defined	25 A eff /=	<= 10 Aeff	10 A<I<25A	25 A eff /=	25 A eff /=	30 A
Threshold	0,1 Ω	0,1 Ω	0,1 Ω	0,5 Ω	≤ 0,2 Ω	0,1 Ω	0,1 Ω	0,1 Ω
Time	Not defined	Not defined	Not defined	Not defined	>5s	Not defined	1 mn	≥ 2 mn

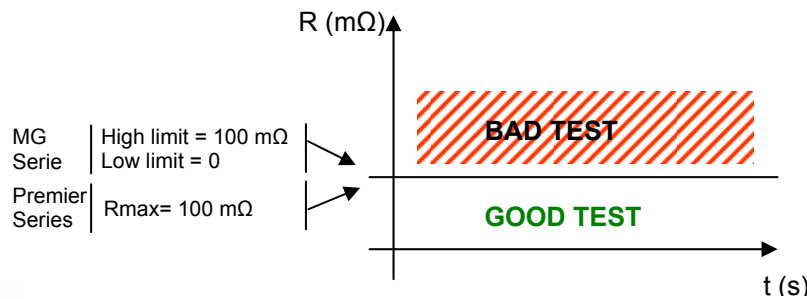

Principle drawing

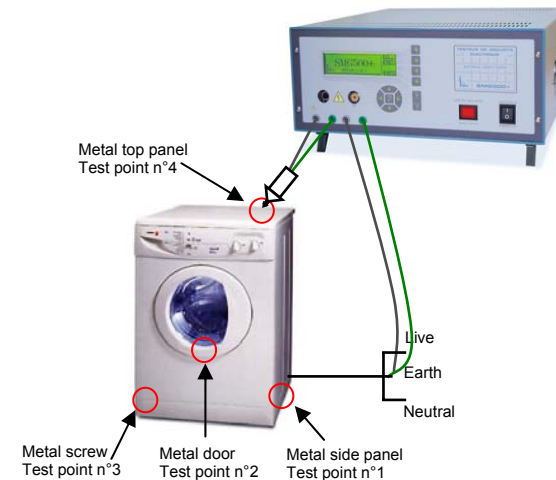

Help file for most popular standards

INSULATION TEST

GOAL: check the insulation and materials quality

PRINCIPLE: Apply during a defined time a stable continuous voltage, measure the resulting current in between the two parts under test and check with the Ohmic law that the insulation resistance is **higher** than the minimum value required by the standard. Generally phase and neutral are shunted and the test is made between those 2 shunted points against the ground point. The DUT is not connected to mains !

TEST CONDITIONS (according to the main standards):

- ◆ Voltage 500 V DC
- ◆ Time 1 min
- ◆ Resistance > 1 MΩ to 10 MΩ

Test parameters

	EN60065	EN60204-1	EN60335-1	EN60598-1	EN60601-1	EN60950	EN61010-1	EN61131-2
Voltage	500 v DC	500 v DC	500 v DC	500 v DC	<i>no insulation</i>	500 v DC	<i>no insulation</i>	<i>no insulation</i>
Threshold	2 to 4 MΩ	1 MΩ	2 to 7 MΩ	2 MΩ	<i>no insulation</i>	2 MΩ	<i>no insulation</i>	<i>no insulation</i>
Time	1 min.	not defined	1 min.	1 min.	<i>no insulation</i>	not defined	<i>no insulation</i>	<i>no insulation</i>

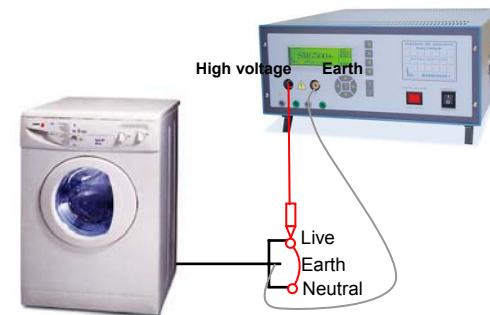
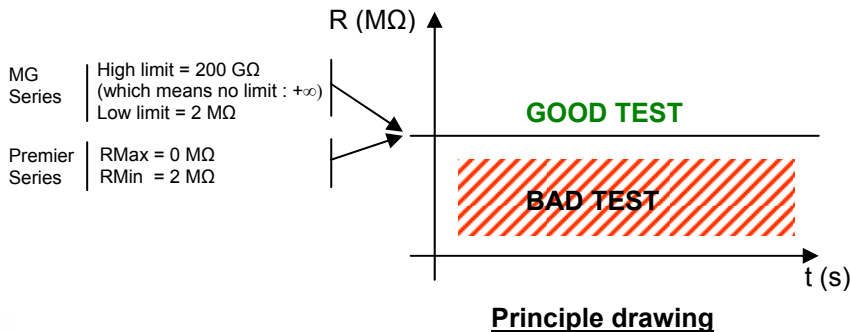

HIGH VOLTAGE TEST (also called hipot test, flash test, dielectric strength test)

GOAL: check that insulation distances and distances in the air are respected.

PRINCIPLE: Apply during a defined time a DC or AC voltage, measure the resistance in between the two parts under test and check with the Ohmic law that the current is **lower** than the value required by the standard. Generally phase and neutral are shunted and the test is made between those 2 shunted points against the ground point. The DUT is not connected to mains!

TEST CONDITIONS (according to the main standards):

- ◆ Voltage from 230 to 15 kV (50 or 60 Hz) or from 330 to 20 kV in peak chock 1, 2 / 50 μ s
- ◆ Current 200 mA max in short-circuit, or equivalent to 500 VA, or not specified (in this last case, the customer has to defined by himself what is the acceptable current to avoid NPNFO)
- ◆ Time from 1 s minimum to 1 mn
- ◆ Sanction neither perforation, nor flashover

Test parameters

	EN60065	EN60204-1	EN60335-1	EN60598-1	EN60601-1	EN60950	EN61010-1	EN61131-2
Voltage	2U + 1410 2120 or 4240	85% U _{tem} 1,5 kV min	0,5 to 3,75 kV	2U + 1000 U + 3000	2U + 1000 2U + 2000 2(2U+1500)	0,5 to 3 kV	0,23 to 5,5 kV * or surge test	2U + 1000 or 0,35 to 4,23 kV AC or 0,5 to 6 kV DC or surge test
Network type		AC	50-60 Hz	50-60 Hz	50-60 Hz	50-60 Hz or DC	50-60 Hz or DC	AC or DC
Mode	U/2 \Leftrightarrow U	not defined	U/2 \Leftrightarrow U	U/2 \Leftrightarrow U	U/2 \Leftrightarrow U	0 to U prog.	10 s. _ / + 1min.	variable according to AC or DC
Power	500 VA	500 VA	500 VA	I _g > 200 mA	Not defined	not defined	not defined	I _{cc} < 5 mA
Time	1 min.	1 min.	1 min.	1 min.	1 min. (1 s.)	1 min. (1 s.)	1 min.	1 s. (1,2 x U)** 1 min./3 periods
Threshold	N.P.N.FO*	not defined	N.P.N.FO.*	N.P.N.FO.*	N.P.N.FO.*	N.P.N.FO.*	N.P.N.FO.*	no breakdown no rupture

N.P.N.FO: neither perforation nor flash over; no current threshold defined

* pollution degree I overvoltage I

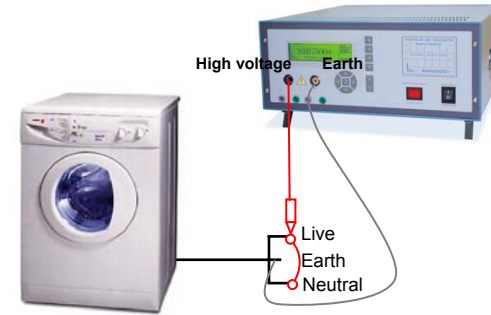
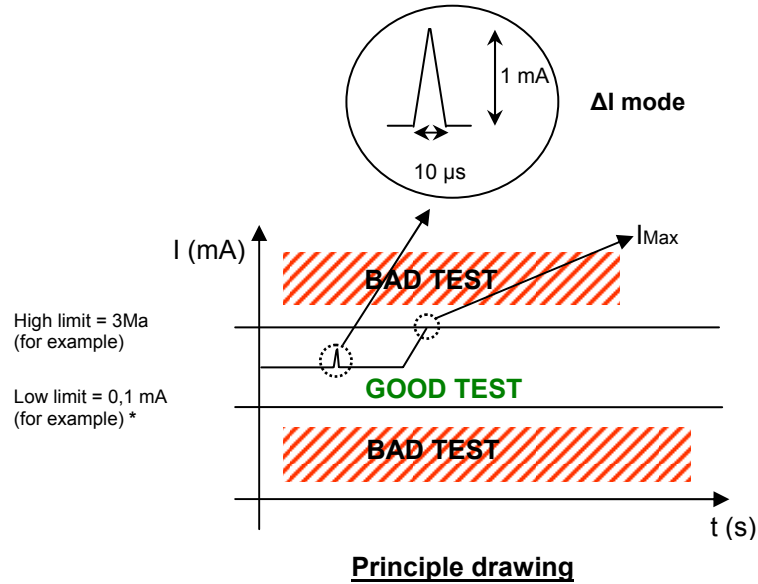

* This limit checks that a minimum current is going through the DUT, in order to be sure the DUT is well connected to the test equipment.

LEAKAGE CURRENT

GOAL: check, under the normal working conditions (equipment powered), the leakage current from the power supply according to the accessible parts, is below than the maximum authorised value.

PRINCIPLE: Power the equipment under test at the nominal voltage through an insulation transformer and measure the leakage current in between each line (phase or neutral) and the protective earth. **This test is the only one that requires the DUT to be powered.**

TEST CONDITIONS (according to the main standards):

- ◆ Voltage (power supply) nominal voltage, nominal voltage + 6%, or nominal voltage + 9%, or nominal voltage + 10%,
- ◆ Current limit from 0,5 to 7 mA (<1 kHz) or 2 mA in DC
- ◆ Measurement circuit 1 750 Ω or 2 000 Ω

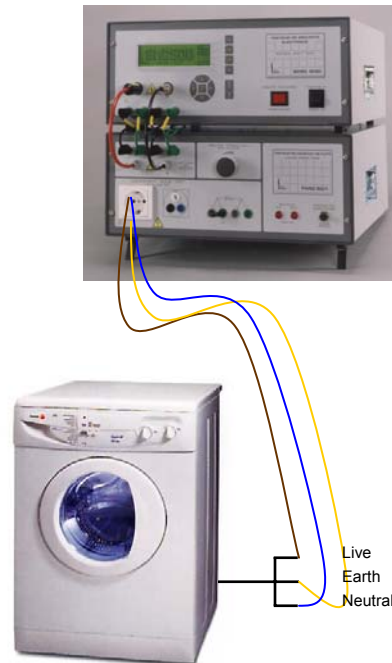

Test parameters

	EN60065	EN60204-1	EN60335-1	EN60598-1	EN60601-1	EN60950	EN61010-1	EN61131-2	IEC990
Voltage (power supply)	Un x 0,9 Un x 1,06	<i>no leakage</i>	U nominal Un x 1,06	U nominal	Un x 1,1	U nominal (<1 kHz)	Un x 1,1	<i>no leakage</i>	
Current threshold	0,7 mA max		0,5 mA 3,5 mA	0,5 - 1 mA 5 mA max.	10 µA to 10 mA	0,5 mA 3,5 mA	3,5 mA AC or 15 mA DC		
Measure circuit	50 kΩ or 2 kΩ		Figure 4 of IEC990	Figure 4 & 5 of IEC990	Figure EN60601	Figure 4 of IEC990	Figure A.1, A.2, A.3		IEC990 standard

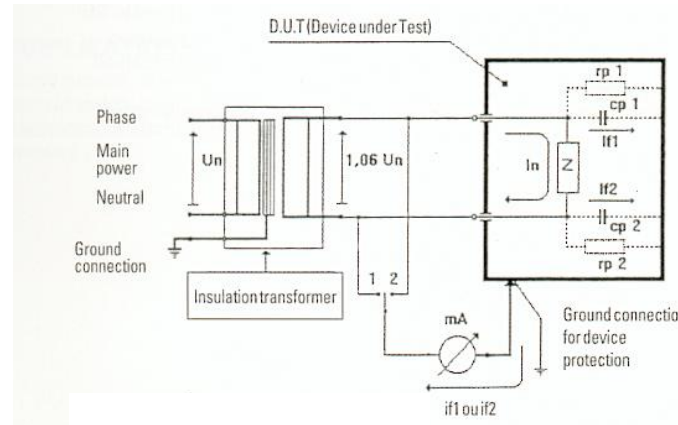
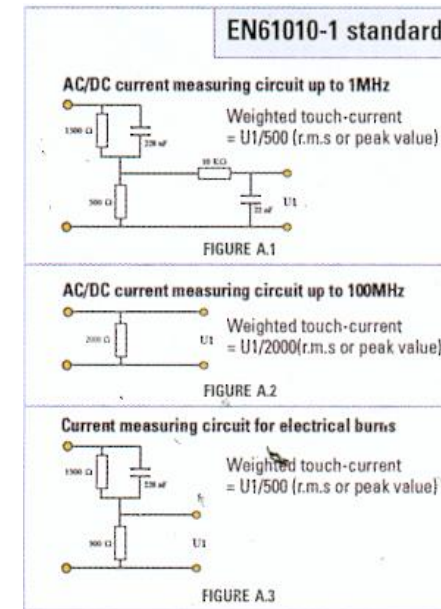
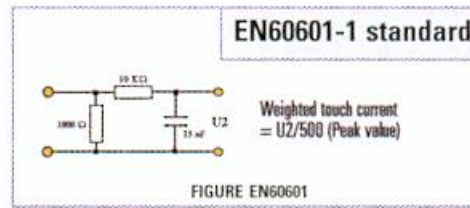
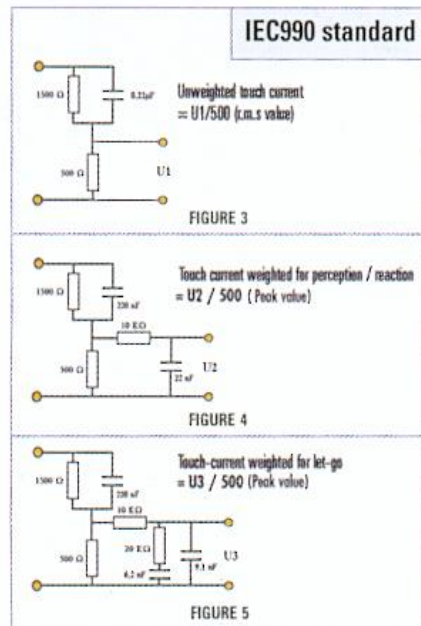

OTHER TEST TYPES AND SPECIFIC TESTS

We can provide the following other tests on customer requirements:

- checking of the stored charges after 10 seconds
- measurement of the accessible transitory voltages in condition of first default (values and times)
- level of charged capacitance in condition of first default
- test to the currents shocks
- overload tests on transformers, engines ...

CONCLUSION

The product quality conception and supervision under the **Low Voltage Directive** makes compulsory the use, towards laboratories and production lines, of a specialised range of test and measurement instruments for normalised electrical tests.

The choice of adapted test and measurement instruments or test systems allow a quick installation optimising a compulsory investment obliged by international standards.

It is also your mission to advice and make aware our customers that they have to do those tests for production criterias, product quality and user safety.

Get more information on the LVD on : http://europa.eu.int/comm/enterprise/electr_equipment/lv/